

# Year 12 PHYSICS ATAR

Semester 1 Examination, 2016

Question/Answer Booklet

Student Number: In figures

--	--	--	--	--	--	--	--

In words

# Solutions

## Time allowed for this paper

Reading time before commencing work: ten minutes

Working time for paper: three hours

## Materials required/recommended for this paper

### To be provided by the supervisor

This Question/Answer Booklet

Formulae and Constants Sheet

### To be provided by the candidate

Standard items: pens, pencils, eraser, correction fluid, ruler, highlighters

Special items: non-programmable calculators satisfying the conditions set by the Curriculum Council for this course

## Important note to candidates

No other items may be taken into the examination room. It is your responsibility to ensure that you do not have any unauthorised notes or other items of a non-personal nature in the examination room. If you have any unauthorised material with you, hand it to the supervisor **before** reading any further.

## ***Structure of this paper***

Section	Number of questions available	Number of questions to be answered	Suggested working time (minutes)	Marks available	Percentage of exam
Section One: Short response	15	15	50	54	30
Section Two: Problem-solving	6	6	90	90	50
Section Three: Comprehension	2	2	40	36	20
				<b>Total</b>	<b>100</b>

## ***Instructions to candidates***

1. The rules for the conduct of Western Australian external examinations are detailed in the *Year 12 Information Handbook 2016*. Sitting this examination implies that you agree to abide by these rules.
2. Write answers in this Question/Answer Booklet.  
  
When estimating numerical answers, show your working or reasoning clearly. Give final answers to a maximum of two significant figures and include appropriate units where applicable.
4. You must be careful to confine your responses to the specific questions asked and to follow any instructions that are specific to a particular question.
5. Spare pages are included at the end of this booklet. They can be used for planning your responses and/or as additional space if required to continue an answer.
  - Planning: If you use the spare pages for planning, indicate this clearly at the top of the page.
  - Continuing an answer: If you need to use the space to continue an answer, indicate in the original answer space where the answer is continued, i.e. give the page number. Fill in the number of the question(s) that you are continuing to answer at the top of the page.

**SECTION ONE: Short Response**

**30% (54 marks)**

This section has 15 questions. Answer all questions.

Suggested working time: 50 minutes.

---

**Question 1**

**(4 marks)**

A charged particle of charge +155 nC has a mass of 2.10 g and is in an electric field as shown below. The particle is suspended because the force of gravity down is equal and opposite to the electric force which is up. Find the magnitude of the electric field strength between the plates.

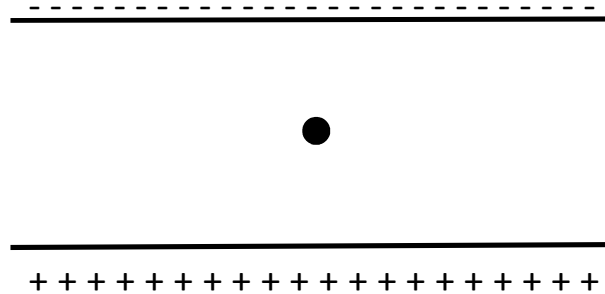

$$F_E = F_g$$

$$Eq = mg \quad \text{grams to kg } \checkmark \text{ concept}$$

$$E = mg/q \quad \checkmark$$

$$= (0.0021)(9.8)/155 \times 10^{-9} \quad \checkmark$$

$$= 1.33 \times 10^5 \text{ N/C (V/m)} \quad \checkmark$$

**Question 2**

**(3 marks)**

Two cannons fire identical cannonballs at identical speeds and at identical angles of  $45^\circ$  to the horizontal. Cannon A is at ground level and cannon B is 25 m above ground level. Which cannon will fire its cannonball with the greatest horizontal range? Justify your answer. You may ignore the effects of air resistance.

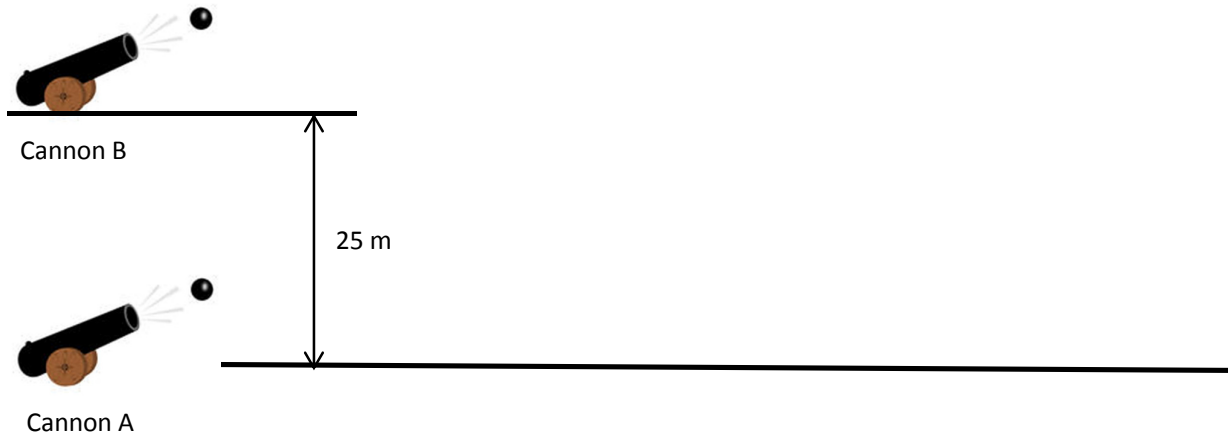

Cannon B ✓

Cannon B will have a greater "time of flight" as it has a greater vertical displacement ✓

Both cannons have same horizontal velocity, but cannon B will have greater horizontal displacement as  $S_H = V_H \times t$  ✓

**Question 3**

**(2 marks)**

A shot-putter throws a shot at an angle to the horizontal. Air resistance is negligible.

Which of the following graphs best represents the **horizontal component** of the shot's velocity from the time it is launched to the time just before it hits the ground?

C ✓

Which of the following graphs best represents the **vertical component** of the shot's velocity from the time it is launched to the time just before it hits the ground?

B ✓

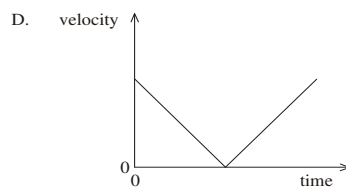
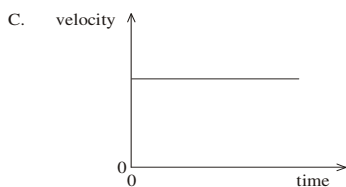
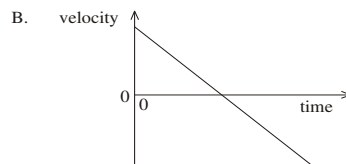
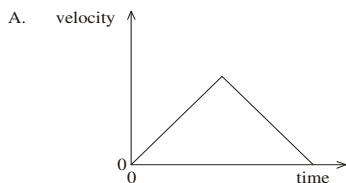

**Question 4**

**(4 marks)**

A 0.75 m metal rod is pushed to the left at  $8.0 \text{ m s}^{-1}$  as shown in the diagram. It is in contact with two conducting rails that make a circuit with a  $5.0 \Omega$  resistor. There is a  $0.25 \text{ T}$  magnetic field directed *out of the page*. Find the magnitude of the induced current passing through the resistor and show the direction of the induced current at position "X".

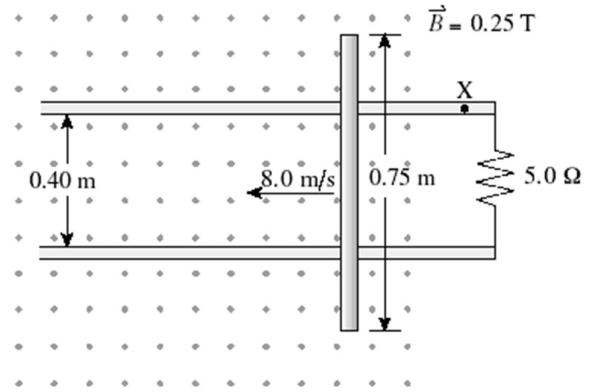

$$\begin{aligned}
 \text{emf} &= lvB \\
 &= 0.40 \times 8.00 \times 0.25 \quad \checkmark \\
 &= 0.800 \text{ V} \quad \checkmark
 \end{aligned}$$

$$\begin{aligned}
 I &= \text{emf}/R \quad \checkmark \\
 &= 0.8/5.0 \\
 &= 0.160 \text{ A} \quad \checkmark
 \end{aligned}$$

**Question 5**

**(3 marks)**

A  $25.0 \text{ kg}$  sign is suspended by two cables as shown in the diagram. The cables make an angle of  $105^\circ$  with each other and have the same length. Find the tension in each cable.

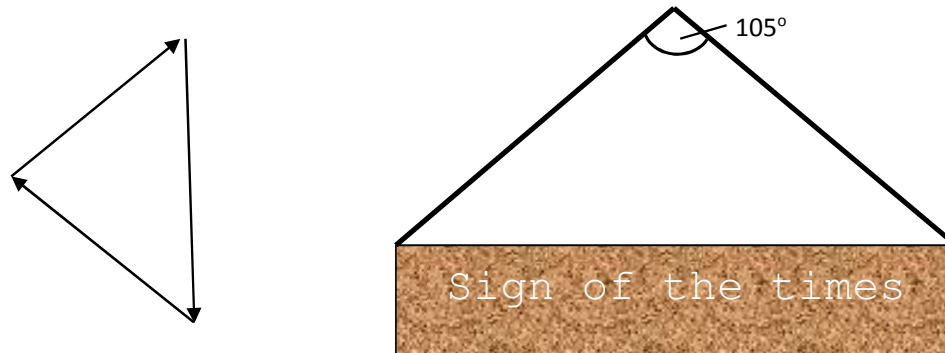

Each cable will have the same tension "T" (symmetry)

$$\Sigma F_y = 0$$

$$2T \sin 37.5 \quad \checkmark \quad = 25 \times 9.8 \quad \checkmark$$

$$T = 201 \text{ N} \quad \checkmark$$

**Question 6**

**(2 marks)**

A simple AC generator was connected to a cathode ray oscilloscope and the coil was rotated at a constant rate. The output is shown on this graph below.

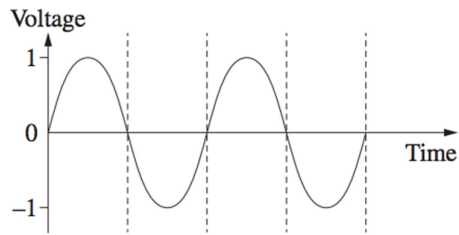

On the axes below, sketch how the output would look if the speed of rotation was halved.

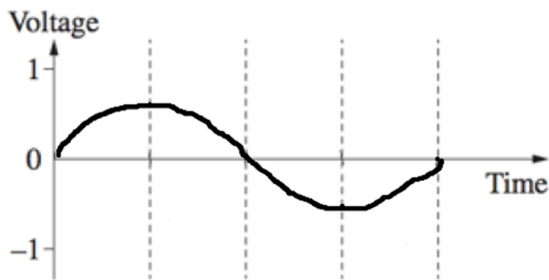

*Period doubled ✓*  
*Amplitude halved ✓*

**Question 7**

**(4 marks)**

The diagram below shows an ideal transformer. When the switch is closed, the galvanometer deflects and then returns to a zero reading. The galvanometer detects current and its direction.

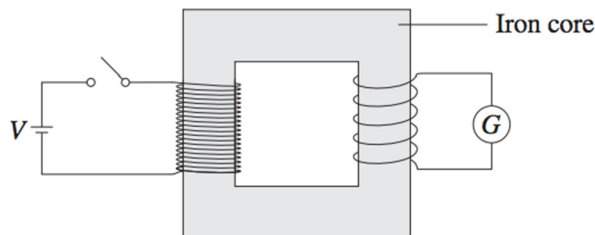

Explain why the galvanometer only shows a reading for a brief moment and then returns to zero.

*As the switch is closed, current increases in the primary coil, which produces a magnetic field. So the secondary coil experiences a momentary change in flux ✓*  
*Therefore a momentary emf is induced in the secondary coil ✓*

State two ways of increasing the magnitude of deflection on the galvanometer.

- 1. decrease the turns ratio  $N_s/N_p$  for lower V and higher I (must be supported) ✓*
- 2. Increase V battery ✓*

**Question 8**

**(3 marks)**

The diagram below shows an aerial view of a train that is travelling in a straight line due west. Hamish rolls a ball directly between points A and B. However, the ball takes the path as shown. What can be inferred about the motion of the train? Explain your answer.

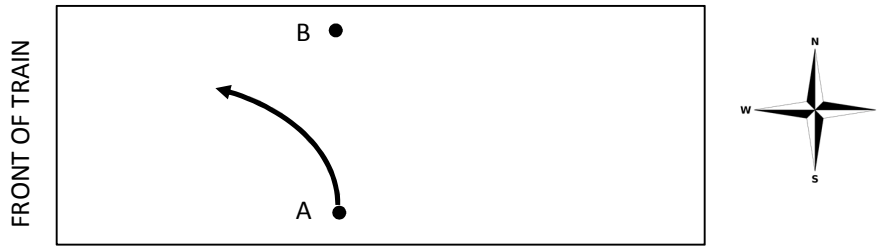

The train is decelerating (i.e. accelerating East)✓  
 The ball has inertia in the Westerly direction so continues forward as the train is slowing ✓  
 Therefore the ball takes a parabolic path as shown ✓  
 (or words to that effect)

**Question 9**

**(4 marks)**

The diagram shows the coil in an AC generator being made to rotate anti-clockwise as viewed from above. The frequency of rotation is constant. The length of wire closest to the North pole is next to the front edge of that pole. Circle responses.

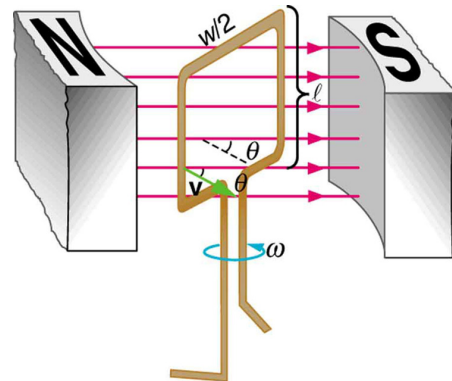

a) The direction of induced current on the length of wire  $l$  closest to the back edge of the South magnetic pole is:

- Up      Down      Impossible to determine

b) In the position shown, the plane of coil makes an angle  $\theta = 35^\circ$  to the magnetic field lines. The emf will change direction in how many degrees of rotation:

- 35°      65°      55°      145°

c) How is the magnitude of emf changing at the position shown?

- Increasing      Decreasing      No change      Impossible to determine

Explain briefly:

The rate of change of flux is between maximum (when zero flux contained in the coil) and zero (maximum flux contained in the coil). So to get from maximum to zero the rate of change must be decreasing.

**Question 10****(5 marks)**

A toy car of mass 125.0 g is on a track that forms part of a vertical circle of radius of 1.50 m. At the lowest point the car has a speed of 4.20 m s<sup>-1</sup>.

- a) Put arrows on the diagram to show the forces acting on the car as a free body diagram. Then make a vector diagram to the left of the diagram and show the sum of forces as an arrow labelled “ΣF”

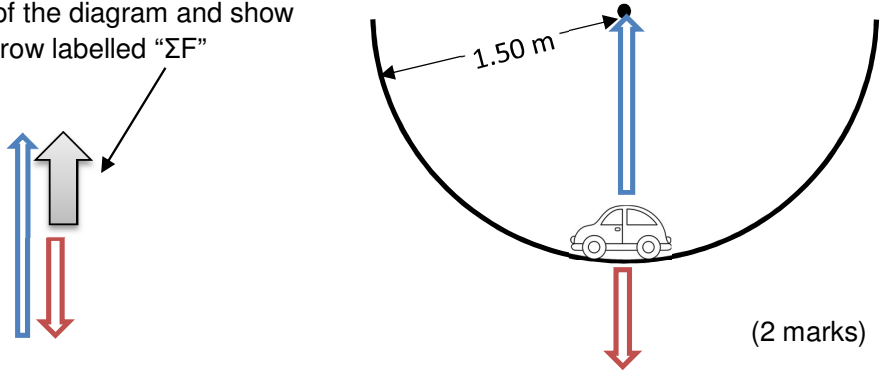

(2 marks)

- b) Calculate the force exerted by the track on the car at this point.

(3 marks)

$$F_{\text{net}} = R - mg \quad \checkmark$$

$$R = mv^2/r + mg \quad \checkmark$$

$$= (0.125)(4.20)^2/1.5 + (0.125)(9.8) \quad \checkmark$$

$$= 2.70 \text{ N} \quad \checkmark$$

**Question 11****(3 marks)**

Kepler's third law is defined as: "The square of the orbital period of a planet is directly proportional to the cube of the radius of its orbit", or as is on the data sheet:

$$\frac{T^2}{r^3} = \frac{4\pi^2}{GM}$$

Beginning with Newton's Universal Law of gravitation **and** the formula for centripetal force (both on the data sheet); derive Kepler's third law. *Full working must be shown.*

$$F_c = F_g$$

$$mv^2/r = GMm/r^2 \quad \checkmark$$

$$v = 2\pi r/T$$

$$(2\pi r/T)^2 = GM/r \quad \checkmark$$

$$4\pi^2 r^2/T^2 = GM/r$$

$$T^2/r^2 = 4\pi^2/GM \quad \checkmark$$



**Question 12**

**(5 marks)**

A motorised model car of mass 1.8 kg is travelling around a banked track of radius 1.5 m. The track is banked so that there is no sideways friction between the car and the track. The car travels a constant speed of 2.0 m s<sup>-1</sup>.

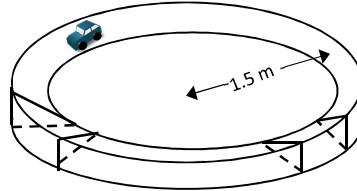

Construct a vector diagram. Show the net force.

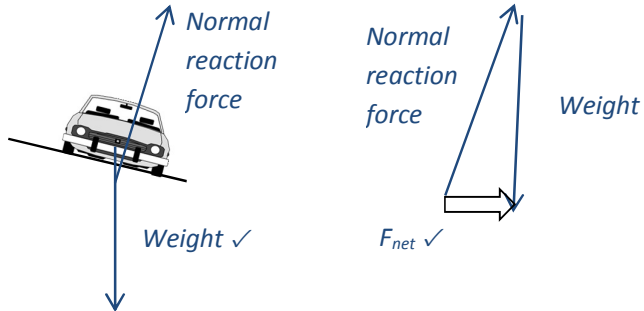

(2 marks)

Find the required banking angle for there to be no sideways friction required.

(3 marks)

$$\begin{aligned}
 \text{Derive } \theta &= \tan^{-1}(v^2/rg) \checkmark \\
 &= \tan^{-1}(2.0^2/(1.5)(9.8)) \checkmark \\
 &= 15.2^\circ \checkmark
 \end{aligned}$$

**Question 13**

**(4 marks)**

The diagram below shows a conductor carrying a 234 mA current in the direction shown. Point P is 23.5 cm from the conductor and on the same plane. State the direction of the magnetic field at P and find the magnetic field strength at this point.

Direction of field is into page  $\checkmark$

$$\begin{aligned}
 B &= (\mu_0/2\pi)(I/r) \checkmark \\
 &= (2 \times 10^{-7})(0.234/0.235) \checkmark \\
 &= 1.99 \times 10^{-7} \text{ T } \checkmark
 \end{aligned}$$

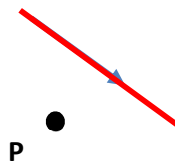

**Question 14****(4 marks)**

A beam of electrons is moving at a speed of  $3.44 \times 10^7 \text{ ms}^{-1}$  and enters a region of perpendicular magnetic field of strength 0.150 T, as shown in the diagram below.

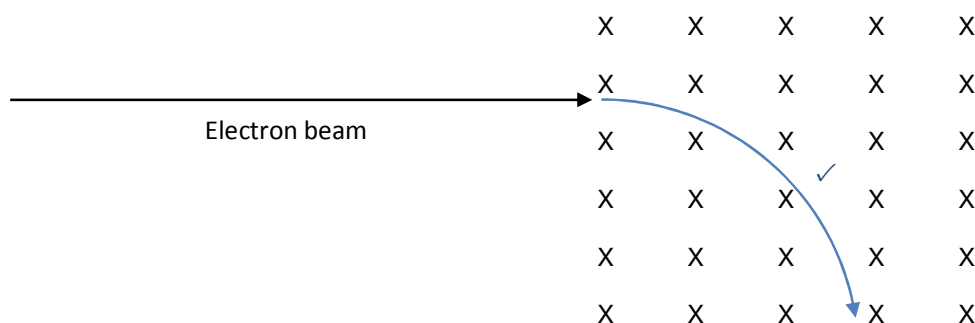

- (a) What is the direction of the magnetic force on the electrons in the beam as they enter the region of magnetic field? Circle the correct answer:

LEFT      RIGHT      **DOWN** ✓      UP      INTO PAGE      OUT OF PAGE

**(1 mark)**

- (b) Calculate the size of the magnetic force acting on **each** electron in the beam as it enters the region of magnetic field.

**(2 marks)**

$$\begin{aligned}
 F &= Bvq \\
 &= (0.150)(3.44 \times 10^7)(1.6 \times 10^{-19}) \checkmark \\
 &= 8.26 \times 10^{-13} \text{ N } \checkmark
 \end{aligned}$$

- (c) On the diagram above, sketch the approximate path that the electron beam will take as it moves through the region of magnetic field.

**As above**

**Question 15**

**(4 marks)**

A metal block of mass 12.0 kg is at rest on a frictionless inclined plane. It is held in position by a horizontal force acting as shown on the diagram. The angle of incline of the plane is  $34.0^\circ$

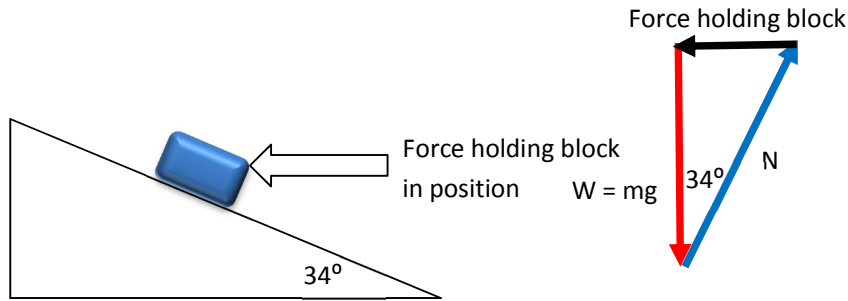

a) Calculate the magnitude of the holding force

(2 marks)

Reference to vector diagram

$$F = mg \tan 34 = 12 \times 9.8 \times \tan 34 \checkmark$$

$$F = 79.3 \text{ N} \checkmark$$

There is a normal reaction force acting on the block both when the holding force is present and when the holding force is withdrawn allowing the block to accelerate along the inclined plane.

b) What happens to the magnitude of the normal reaction force when the holding force is withdrawn? The normal reaction force: (circle a response)

(2 marks)

Increases

Stays the same

Decreases

Explain briefly:

Reference to vector diagram

Now only 2 forces act such that sum of forces parallel to plane, previously a component of the normal reaction was acting against the holding force  $\checkmark$

Any acceptable explanation

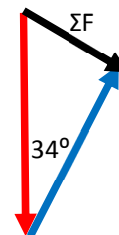

**End of Section One**

**SECTION TWO: Problem-solving****50% (90 marks)**

This section has **six (6)** questions. Answer **all** questions. Write your answers in the spaces provided.

Suggested working time: 90 minutes.

**Question 16****(14 marks)**

Amy launches herself in the air and kicks a soccer ball at  $10.0 \text{ m s}^{-1}$ . She kicks the ball from a height of  $1.56 \text{ m}$  above ground level. The ball reaches a maximum height of  $5.73 \text{ m}$  above the ground. The ball has a mass of  $450 \text{ g}$ .

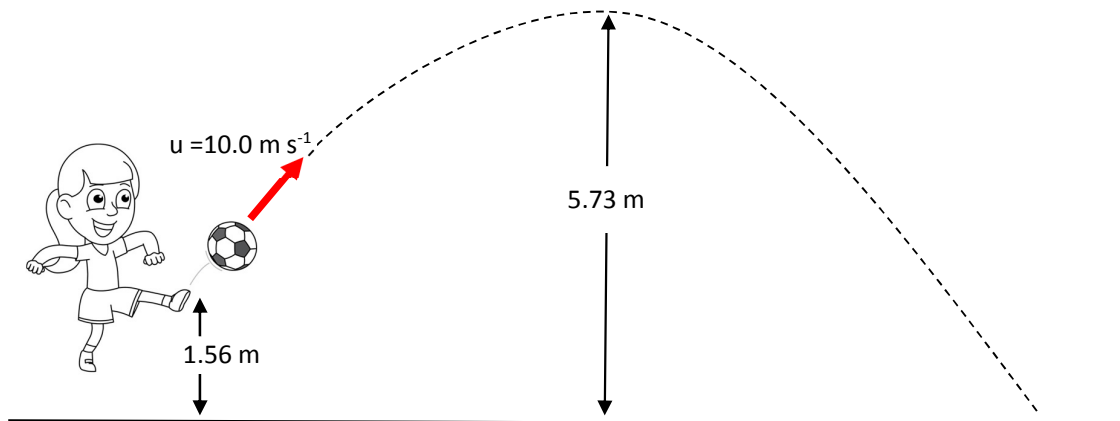

a) Calculate angle to the horizontal that the ball was kicked.

(4 marks)

At max height  $v_v = 0$

$$v^2 = u^2 + 2as$$

$$0^2 = u_v^2 + 2(-9.8)(4.17) \checkmark$$

$$u_v = 9.04 \text{ m/s} \checkmark$$

$$10.0 \sin\theta = 9.04 \text{ m/s} \checkmark$$

$$\theta = 64.7^\circ \checkmark$$

- b) Determine the ball's speed at its maximum height. If you could not determine the launch angle in the previous question use a value of  $64.7^\circ$ . If your previous answer differs by more than half a degree then use a value of  $64.7^\circ$  for the following questions.

(2 mark)

$$\begin{aligned} u_h &= u \cos \theta \\ &= 10.0 \cos 64.7 \\ &= 4.274 = 4.27 \text{ m/s } \checkmark \end{aligned}$$

- c) Calculate the horizontal range of the kick.

For vertical:

$$\begin{aligned} v_v^2 &= u_v^2 + (2)(a)(s) && (4 \text{ marks}) \\ &= (9.04)^2 + 2(-9.80)(-1.56) \\ v_v &= -10.597 \text{ m/s } \checkmark \end{aligned}$$

$$\begin{aligned} t &= (v_v - u_v) / a \\ &= (-10.597 - 9.04) / -9.8 \\ &= 2.00 \text{ s } \checkmark \end{aligned}$$

For horizontal:

$$\begin{aligned} s_h &= u_h \times t \\ &= (4.274)(2.00) \\ &= 8.548 \text{ m } \checkmark = 8.55 \text{ m} \end{aligned}$$

- d) Calculate the kinetic energy that the ball has as it reaches the ground (just before impact)

For vertical:

(4 marks)

$$\begin{aligned} v_v &= -10.597 \text{ m/s} \\ u_h &= 4.274 \text{ m/s} \end{aligned}$$

$$\text{Overall speed by Pythagoras} = \sqrt{4.274^2 + 10.597^2} \checkmark$$

$$v = 11.426 \checkmark$$

$$\text{KE} = \frac{1}{2} m v^2 = 0.5 \times 0.450 \times 11.426^2 \checkmark$$

$$\text{KE} = 29.4 \text{ J}$$

**Question 17****(12 marks)**

An alpha particle consists of two protons and two neutrons and has a mass of  $6.64 \times 10^{-27}$  kg and a charge of  $+3.20 \times 10^{-19}$  C.

(a) Calculate the force of repulsion between two alpha particles that are 0.150 nm apart. (2 marks)

$$\begin{aligned}
 F &= \frac{1}{4\pi\epsilon_0} \frac{q_1 q_2}{r^2} \\
 &= \frac{1}{4\pi(8.85 \times 10^{-12})} \times (3.2 \times 10^{-19})^2 / (0.15 \times 10^{-9})^2 \quad \checkmark \\
 &= 4.09 \times 10^{-8} \text{ N} \quad \checkmark
 \end{aligned}$$

In a particle accelerator, an alpha particle is accelerated from rest through a potential difference of 2.40 kV.

(b) Find the work done on the particle by the electric field and hence the final speed of the particle. (3 marks)

$$\begin{aligned}
 W &= qV \\
 &= (3.2 \times 10^{-19})(2.40 \times 10^3) \\
 &= 7.68 \times 10^{-16} \text{ J} \quad \checkmark \\
 \\ \\
 KE &= \frac{1}{2} mv^2 \\
 7.68 \times 10^{-16} &= \frac{1}{2} (6.64 \times 10^{-27})v^2 \quad \checkmark \\
 v &= 4.81 \times 10^5 \text{ m/s} \quad \checkmark
 \end{aligned}$$

The alpha particle then enters a region between two parallel plates that are 60.0 mm apart. There is a potential difference of 550 V between the plates. The metal plates are 2.50 cm long. The particle enters the region between the plates midway between the plates.

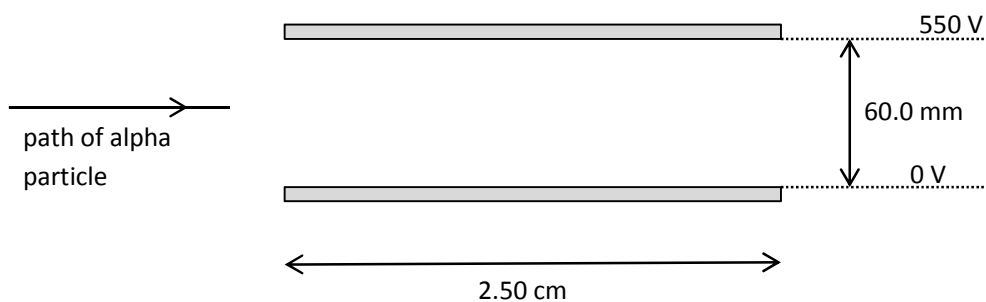

- c) Demonstrate by calculation that the electric field strength between the two plates has a magnitude of  $9170 \text{ N C}^{-1}$ .

(2 marks)

$$\begin{aligned} E &= V/d \\ &= 550/0.06 \checkmark \\ &= 9170 \text{ V/m (N/C)} \checkmark \end{aligned}$$

- d) Demonstrate by calculation that the acceleration of the alpha particle as it passes between the plates is equal to  $4.42 \times 10^{11} \text{ m s}^{-2}$

(2 marks)

$$\begin{aligned} a &= F/m \\ &= qE/m \checkmark \\ &= (3.2 \times 10^{-19})(9170)/6.64 \times 10^{-27} \\ &= 4.42 \times 10^{11} \text{ m/s}^2 \text{ down } \checkmark \end{aligned}$$

- e) Does the alpha particle pass through the plates or does it hit one of the plates? Justify your answer with suitable calculations. You can assume that the horizontal component of speed entering this region remains constant at  $4.81 \times 10^5 \text{ m s}^{-1}$ .

(3 marks)

$t$  to pass through plates:

$$\begin{aligned} t &= d/v \text{ (av)} \\ &= 0.025/4.81 \times 10^5 \\ &= 5.20 \times 10^{-8} \text{ s } \checkmark \text{ (allow follow through if prev calc v used)} \end{aligned}$$

$$\begin{aligned} s_v &= ut + \frac{1}{2} at^2 \\ &= (\frac{1}{2})(4.42 \times 10^{11})(5.20 \times 10^{-8})^2 \\ &= 5.97 \times 10^{-4} \text{ m} < 0.6 \text{ mm } \checkmark \text{ therefore will pass through } \checkmark \end{aligned}$$

**Question 18**

**(14 marks)**

A 25.0 kg uniform beam PQ is supporting a 60 kg load as shown in the diagram. A cable AB is attached 2.0 m from a frictionless hinge at P, at right angles.

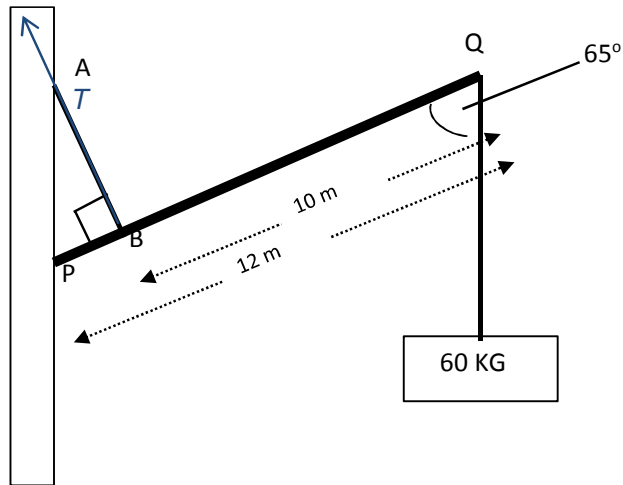

(a) Find the tension in the cable AB for the position shown.

(3 marks)

Take torques about P:

$$\sum T_{cw} = \sum T_{acw}$$

$$T(2.0) = (245)(6)(\sin 65^\circ) + (588)(12)(\sin 65^\circ) \checkmark \checkmark$$

$$T = 3863.59 = 3,860 \text{ N } \checkmark$$



- (b) Find the (reaction) force exerted on the beam by the hinge at P. Be sure to find the magnitude and direction of this force. (5 marks)

Note:  $T$  is at  $25^\circ$  to the vertical (90-65)

$$\Sigma F_h = 0$$

$$R_h = 3863 \times \sin 25^\circ \\ = 1632.82 \text{ N } \checkmark$$

$$\Sigma F_v = 0$$

$$R_v = 588 + 245 - (3,860 \times \cos 25^\circ) \\ = -2,668.6 \text{ N (i.e. down) } \checkmark$$

$$R^2 = 1632.82^2 + (-2,668.6)^2$$

$$R = 3128.5 = 3,130 \text{ N } \checkmark$$

$$\Theta = \tan^{-1}(2,668/1,632.82) \checkmark$$

$$= 58.5^\circ \checkmark$$

i.e. Reaction force is 3,128 N,  $58.5^\circ$  below horizontal and to the right.

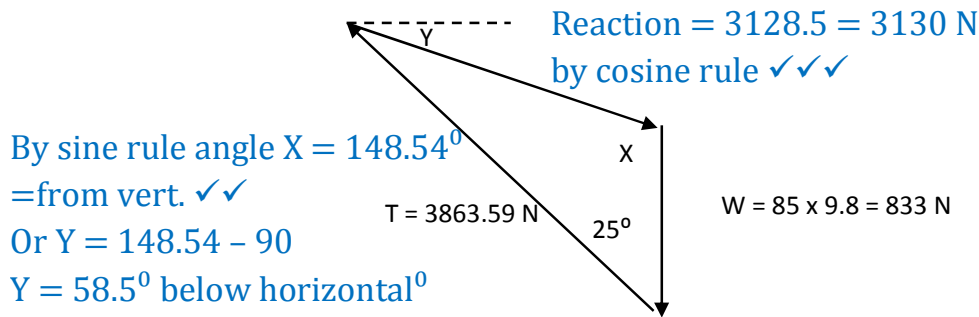

- (c) The beam is then lowered by lengthening cable AB. Explain the effect that this change will have (if any) on the following. Clearly explain your reasoning. (6 marks)

	Change	Explanation
Magnitude of tension in AB	Increase ✓	CW torque increases as both weights lever arm angle is now $90^\circ$ . $T$ increases to provide opposing ACW torque. ✓
Horizontal component of reaction force on beam at P.	Increase ✓	As $T$ increases, so does its horizontal component. So $R_h$ must increase to maintain horizontal equilibrium. ✓
Vertical component of reaction force on beam at P.	Increase ✓	As $T$ increases, so does vertical component of $T$ (which is up). So $R_v$ (which is down) must increase to maintain vertical equilibrium. ✓

**Question 19**

**(17 marks)**

Two Year 12 students were given a model DC motor to experiment with in class. The two magnets provide a uniform magnetic field of 1.50 mT. EFGH is a square coil of side length 5.00 cm with 20 turns. A 6.00 V battery and an ammeter are connected as shown.

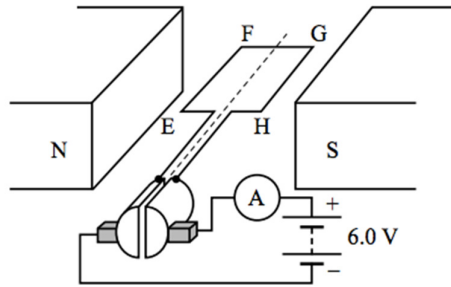

- (a) When the motor is first switched on, the ammeter shows a current of 5.13 A. Find the magnitude and direction of the force on side GH. (2 marks)

$$F = ILBn$$

$$= (5.13)(0.05)(0.0015)(20) \checkmark = 7.70 \times 10^{-3} \text{ N} \checkmark$$

- (b) Once the motor had started spinning, the current dropped to 0.15 A. Explain why the current dropped by making reference to Lenz's Law. (2 marks)

The spinning armature induces an emf whose current establishes a flux to opposes the change  $\checkmark$  This reduces the net emf and thus the current drawn by the motor.  $\checkmark$  i.e back emf

- (c) Is the position shown, a position of maximum or minimum torque? Explain. (2 marks)

Position of maximum torque  $\checkmark$   
 Forces on EF and GH are at an angle of  $90^\circ$  to lever arms from axis of rotation  $\checkmark$

- (d) Find the maximum torque produced by this motor when the current is 5.13 A. (3 marks)

$$\text{Torque}_{\text{max}} = BINA$$

$$= (0.0015)(5.13)(20)(0.05)^2 \checkmark \checkmark$$

$$= 3.85 \times 10^{-4} \text{ N m} \checkmark$$

The students then reconfigure the motor so it operates as a dc generator as shown below. They do this by replacing the battery with a voltmeter and cathode ray oscilloscope to analyse the emf produced.

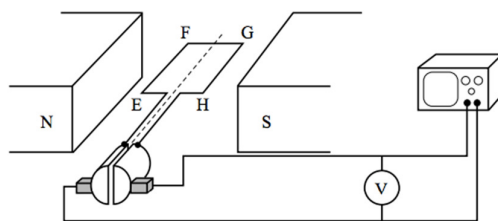

- (e) On the axes below, sketch how the induced emf varies with time as the coil is rotated at a constant rate. No scales on the axes are required. At  $t=0$ , the coil is in the position shown above. Sketch the emf for two complete revolutions. (2 marks)

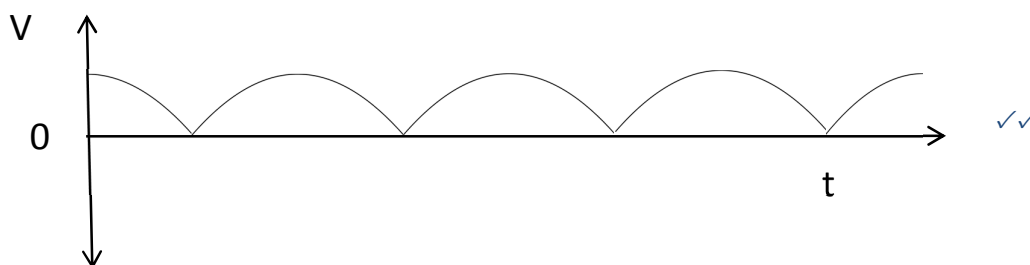

- (f) The students then converted the dc generator into an ac generator, what changes did they need to make? (2 marks)

The students would have replaced the split ring commutator with slip rings ✓ ✓

The students then rotated the **ac generator** at a constant frequency and achieved a maximum emf of 33.0 mV.

- (g) Calculate the frequency of rotation. (3 marks)

$$\begin{aligned} \epsilon_{\max} &= 2\pi N B A f \\ 0.033 &= 2\pi (20)(0.0015)(0.05)^2 f \quad \checkmark \checkmark \\ f &= 70.0 \text{ Hz} \quad \checkmark \end{aligned}$$

- (h) What average (RMS) emf was produced? (1 marks)

$$\begin{aligned} \epsilon_{\text{rms}} &= \epsilon_{\max} / \sqrt{2} \\ &= 0.033 / \sqrt{2} \\ &= 23.3 \text{ mV} \quad \checkmark \end{aligned}$$

**Question 20**

**(18 marks)**

Western Power is trialling an experimental hydroelectric power scheme at Leonora. The town’s main water supply is pumped from Perth and then stored at a considerable height above the town itself in a large dam. Water flowing from the dam to the town is used to turn turbines in the hydroelectric plant. These turbines are connected to ac generators that produce electricity that is “stepped up” to 50 000 V<sub>RMS</sub> before it is transmitted to Leonora via 20 km of transmission lines. At the edge of town, there is a “step down” transformer that converts the voltage to 250 V<sub>RMS</sub> for use in Leonora. The current in the transmission lines is 23.0 A<sub>RMS</sub>. The system is represented below.

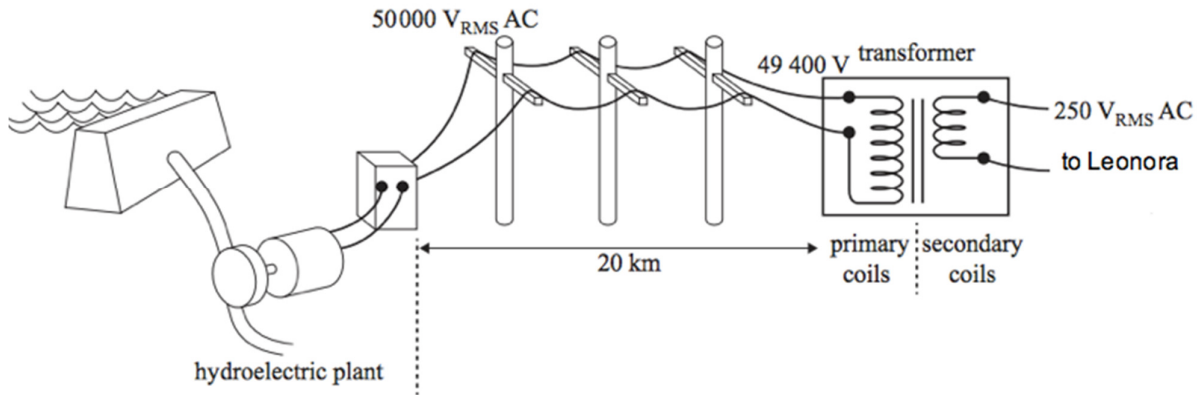

- (a) Find the power provided to the transmission lines. (2 marks)

$$\begin{aligned}
 P &= VI \\
 &= (50000)(23.0) \checkmark \\
 &= 1.15 \times 10^6 \text{ W} \checkmark
 \end{aligned}$$

- (b) Find the resistance of the transmission lines. (2 marks)

$$\begin{aligned}
 V_{\text{drop}} &= IR \\
 R &= 600/23.0 \checkmark \\
 &= 26.0 \Omega \checkmark
 \end{aligned}$$

- (c) What is the percentage of power lost due to the resistance of the power lines? (2 marks)

$$\begin{aligned}
 P_{\text{loss}} &= I^2 R = 23^2 \times 26 = 13754 \text{ W} \\
 \%_{\text{loss}} &= 13754 / (5000 \times 23) \checkmark \\
 &= 1.20 \% \checkmark
 \end{aligned}$$

- (d) There are 50 turns on the secondary side of the transformer. Calculate the number of turns on the primary side. (2 marks)

$$\begin{aligned}
 N_p / N_s &= V_p / V_s \\
 N_p / 50 &= 49400 / 250 \checkmark \\
 N_p &= (49400 \times 50) / 250 = 9880 \checkmark
 \end{aligned}$$

- (e) Explain clearly, why it is essential for Western Power to “step up” the voltage before transmitting electricity to Leonora. (2 marks)

Stepping up the voltage means lower current for equal power ✓  
 so power losses due to the resistance of the lines is reduced ( $I^2R$ ) ✓

- (f) Explain why power utilities such as Western Power transmit ac electricity over large distances and not dc. (2 marks)

ac can be easily stepped up and down via transformers ✓

dc can not be stepped up or down ✓

All transformers have a soft iron core, around which **both** the primary and secondary coils are wound.

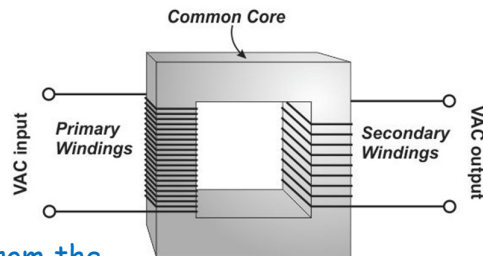

- (g) Explain the purpose of the core?

The soft iron core “channels” magnetic flux from the primary coils to the secondary coils. i.e. the core reduces “flux leakage” .✓✓

- (h) Explain how constructing the core from thin laminations, as shown below, significantly reduces the energy losses in the transformer. (2 marks)

Laminations prevent large eddy currents being induced in the core due the rapidly changing magnetic flux. ✓ Smaller eddy currents are favourable as power lost is proportional to  $I^2$ . ✓

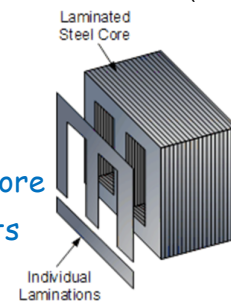

(2 marks)

- (i) An accountant suggests making the core from aluminium to save money and weight. Discuss the effectiveness of this proposal. (2 marks)

Bad idea as aluminium not ferromagnetic ✓

Only ferromagnetic materials have domains to align with dominant magnetic flux so be induced to concentrate the field ✓

**Question 21**

**(15 marks)**

A satellite probe has been placed in various orbits around the planet Venus. Your task is to use this data to determine the mass of Venus. Note that Kepler's 3<sup>rd</sup> law equation has been rearranged below so that orbital radius is related to the independent variable for graph plotting:

$$T^2 = \frac{4\pi^2}{G m_{planet}} r^3$$

- a. Manipulate the data in the table below so you can plot a **y = mx** format. (3)

Orbital radius between centre of masses (m)	$r^3$	Orbital Period of artificial satellite (s)	$T^2$
$1.00 \times 10^7$	$1.00 \times 10^{21}$	11,000	$1.21 \pm 0.12 \times 10^8$
$1.20 \times 10^7$	$1.73 \times 10^{21}$	14,500	$2.10 \pm 0.21 \times 10^8$
$1.40 \times 10^7$	$2.74 \times 10^{21}$	18,300	$3.35 \pm 0.34 \times 10^8$
$1.60 \times 10^7$	$4.10 \times 10^{21}$	22,400	$5.02 \pm 0.50 \times 10^8$
$1.80 \times 10^7$	$5.83 \times 10^{21}$	26,700	$7.13 \pm 0.71 \times 10^8$

Hint: the gradient (m) of the line that you plot should equal  $\frac{4\pi^2}{G m_{planet}}$

- b. Plot your data onto a graph and draw a line of best fit through the data.

Accurate plots with uncertainty, scaling, axes labels, units, LOBF

(5)

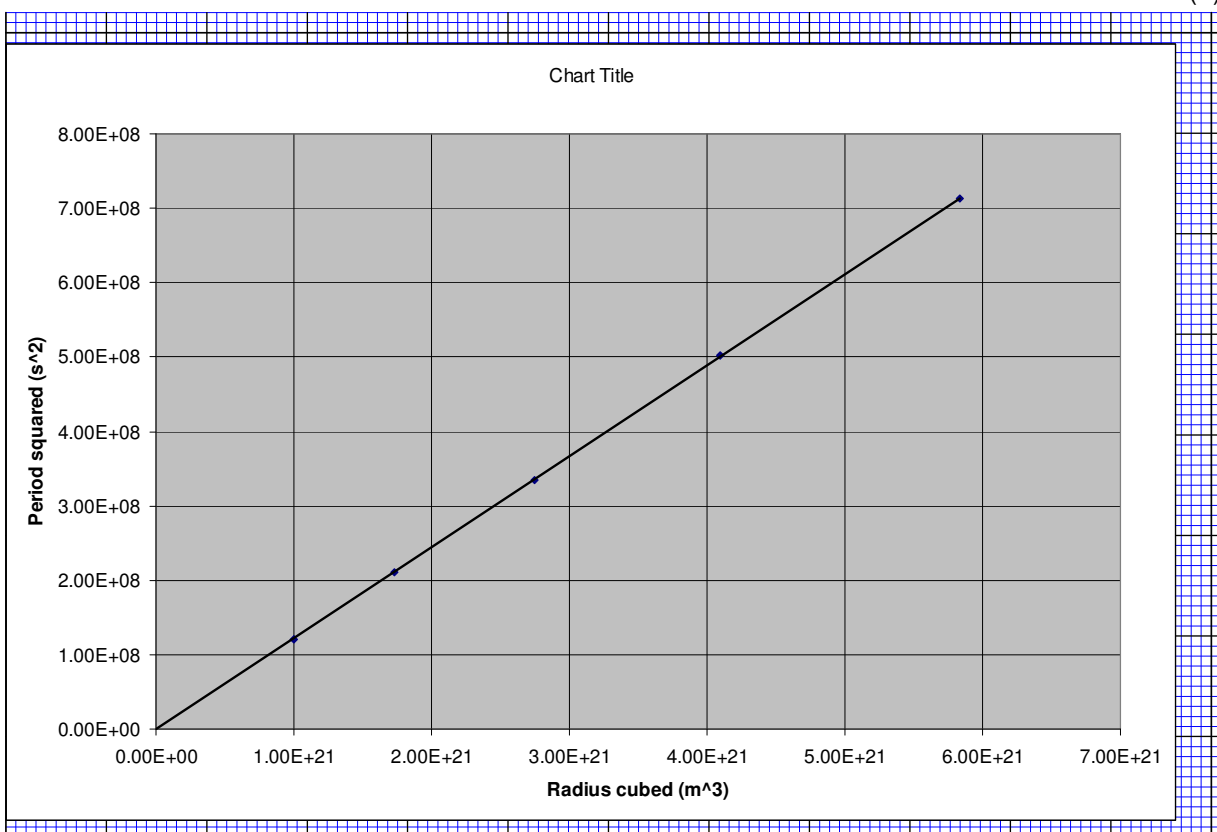

c. Calculate the gradient of your line of best fit.

(3)

$$\text{rise} = 7.0 \times 10^8 \text{ s}^2 \text{ (from graph line of best fit) } \checkmark$$

$$\text{run} = 5.7 \times 10^{21} \text{ m}^3 \text{ (not from data points) } \checkmark$$

$$\text{gradient} = \text{rise} / \text{run} = 7.0 \times 10^8 / 5.7 \times 10^{21}$$

$$\text{gradient} = 1.228 \times 10^{-13} \text{ s}^2 \text{ m}^{-3} \checkmark$$

d. What are the units of the line of best fit?

(1)

$$\text{s}^2 \text{ m}^{-3} \checkmark$$

e. From the gradient of your line of best fit, calculate the mass of the planet Venus.

(3)

$$\text{gradient} = 4\pi^2 / (G M) = 1.228 \times 10^{-13} \checkmark$$

$$M = 4\pi^2 / (6.67 \times 10^{-11} \times 1.228 \times 10^{-13}) \checkmark$$

$$M = 4.82 \times 10^{24} \text{ kg } \checkmark \text{ (allow tolerance)}$$

**End of Section Two**

### SECTION THREE: Comprehension

20% (36 marks)

This section has **two (2) questions**. You must answer **both** questions. Write your answers in the spaces provided.

Suggested working time: 40 minutes.

---

#### Question 22

(18 marks)

### Juno slingshots past Earth on its way to Jupiter

Article adapted from Science Daily's Article: *Juno slingshots past Earth on its way to Jupiter*. October 8, 2013

If you've ever whirled a ball attached to a string around your head and then let it go, you know the great speed that can be achieved through a slingshot maneuver.

Similarly, NASA's Juno spacecraft will be passing within some 563 km of Earth's surface at 3:21 p.m. EDT Wednesday, Oct. 9, 2013 before it slingshots off into space on a historic exploration of Jupiter.

It's all part of a scientific investigation that began with an August 2011 launch. The mission will begin in earnest when Juno arrives at Jupiter in July 2016.

Bill Kurth, University of Iowa research scientist and lead investigator for one of Juno's nine scientific instruments, the Waves instrument, says that the two years spent moving outward past the orbit of Mars before swinging past Earth makes the trip to Jupiter possible.

"Juno will be really smoking as it passes Earth at a speed of about 40 kilometres per second relative to the sun. But it will need every bit of this speed to get to Jupiter for its July 4, 2016 capture into polar orbit about Jupiter," says Kurth, who has been involved with the mission since the beginning. "The first half of its journey has been simply to set up this gravity assist with Earth".

Kurth and colleagues UI Professor Don Gurnett and research scientist George Hospodarsky note that the real science will begin when Juno begins orbiting Jupiter some 33 times over the course of a year. Juno will be the first spacecraft to orbit Jupiter over its poles.

The UI-designed-and-built Waves instrument will examine a variety of phenomena within Jupiter's polar magnetosphere by measuring radio and plasma waves. It's one of nine experiments to be undertaken of the gas giant.

In particular, Juno will explore the solar system's most powerful auroras -- Jupiter's northern and southern lights -- by flying directly through the electrical current systems that generate them.

The Aurora is an incredible light show caused by collisions between electrically charged particles released from the sun that enter a planet's atmosphere and collide with gaseous molecules. The lights are seen around the magnetic poles of the northern and southern hemispheres.

"Jupiter has the largest and most energetic magnetosphere, and to finally get an opportunity to study the nature of its auroras and the role radio and plasma waves play in their generation makes Juno a really exciting mission for me," says Kurth.

Juno's other major objectives include mapping the planet's magnetic and gravity fields to learn more about its deep interior including the size of its core.





Juno's destiny is a fiery entry into Jupiter's atmosphere at the end of its one-year science phase as a means of guaranteeing it doesn't impact Europa and possibly contaminate that icy world with microbes from Earth. This would jeopardise future missions to that moon designed to determine whether life had begun there on its own.

- (a) Juno was launched in July 2011 to explore Jupiter. Explain why the probe's trajectory brought it back to within 600 km of the Earth. (2 marks)

Juno was brought back towards to Earth to take advantage of the "slingshot effect" ✓

This is when the probe interacts with the Earth's gravitational field to increase its TME ✓ (KE increases over an arc)

- (b) On October 9, 2013 Juno was 563 km above the Earth's surface. At this instant it was within metres of another (Low-Earth orbit) satellite. Calculate the speed of this satellite. (3 marks)

Derive

$$\begin{aligned}
 v^2 &= GM/r \quad \checkmark \\
 &= (6.67 \times 10^{-11})(5.97 \times 10^{24}) / (6.37 \times 10^6 + 563000) \quad \checkmark \\
 v &= 7,578.6 = 7.58 \times 10^3 \text{ m/s} \quad \checkmark
 \end{aligned}$$

- (c) The mass of Jupiter is  $1.90 \times 10^{27}$  kg. The diameter of Jupiter is 140 000 km. The Juno craft will be as close as 4,300 km to the surface of Jupiter. Calculate the gravitational field strength of Jupiter at this location.

(3 marks)

$$\begin{aligned}
 g &= GM/r^2 \\
 &= (6.67 \times 10^{-11})(1.90 \times 10^{27}) / (70\,000\,000 \checkmark + 4\,300\,000) \quad \checkmark \\
 g &= 23.0 \text{ N kg}^{-1} \quad \checkmark
 \end{aligned}$$

- (d) The Juno craft will eventually establish a circular orbit that will take 11 Earth days to complete. Calculate the average radius of Juno's circular orbit from Jupiter's centre of mass. The mass of Jupiter is  $1.90 \times 10^{27}$  kg.

$$\begin{aligned}r^3 &= GMT^2/4\pi^2 && (4 \text{ marks}) \\&= (6.67 \times 10^{-11})(1.9 \times 10^{27})(11 \times 24 \times 60 \times 60)^2/4\pi^2 \checkmark\checkmark \\&= 2.94 \times 10^{27} \checkmark \\r &= 1.43 \times 10^9 \text{ m} \checkmark\end{aligned}$$

- (e) Explain why NASA have planned for Juno to orbit over Jupiter's poles. (2 marks)

To investigate Jupiter's magnetic field ✓ and study Jupiter's auroras ✓

- (f) At what location on Jupiter's surface would its magnetic field be the strongest, the poles or the equator? Explain.

(2 marks)

At the poles, ✓ the magnetic flux lines are more closely packed ✓

- (g) Why is NASA planning on crashing Juno into Jupiter at the end of its mission? (2 marks)

To prevent Juno ever crashing into Europa ✓ and contaminating it with microbes from Earth. ✓

## Question 23

(18 marks)

### Three-phase electric power

Article adapted from a Wikipedia article: [https://en.wikipedia.org/wiki/Three-phase\\_electric\\_power](https://en.wikipedia.org/wiki/Three-phase_electric_power)

Three-phase electric power is a common method of alternating-current electric power generation, transmission, and distribution. It is a type of polyphase system and is the most common method used by electrical grids worldwide to transfer power. It is also used to power large motors and other heavy loads. A three-phase system is usually more economical than an equivalent single-phase at the same line to ground voltage because it uses less conductor material to transmit electrical power. The three-phase system was independently invented by Galileo Ferraris, Mikhail Dolivo-Dobrovolsky, Jonas Wenström and Nikola Tesla in the late 1880s.

A simple three phase generator has a spinning magnet that rotates past three different sets of coils.

In a symmetric three-phase power supply system; three conductors each carry an alternating current of the same frequency and voltage amplitude relative to a common reference but with a phase difference of one third the period. The common reference is usually connected to ground and often to a current-carrying conductor called the neutral. Due to the phase difference, the voltage on any conductor reaches its peak at one third of a cycle after one of the other conductors and one third of a cycle before the remaining conductor. This phase delay gives constant power transfer to a balanced load.

In a three-phase system feeding a balanced load, the sum of the instantaneous currents of the three conductors is zero. In other words, the current in each conductor is equal in magnitude to, but with the opposite sign of, the sum of the currents in the other two. This is similar to the phenomenon of “total destructive interference” in wave motion.

Compared to a single-phase AC power supply that uses two conductors (phase and neutral), a three-phase supply with no neutral, the same phase-to-ground voltage and current capacity per phase can transmit three times as much power using just 1.5 times as many wires (i.e. three instead of two). Thus, the ratio of capacity to conductor material is doubled.

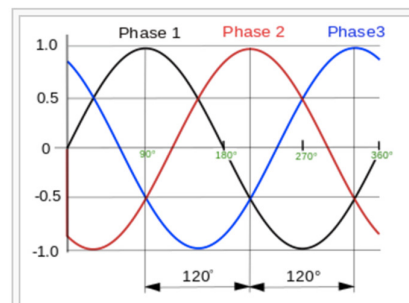
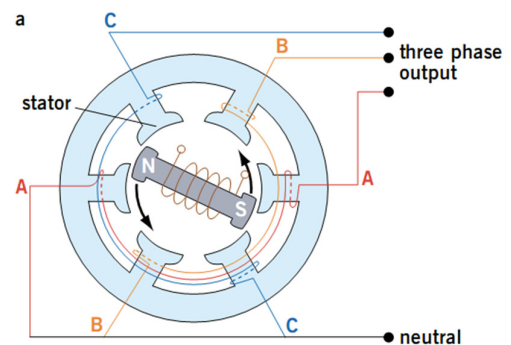

Normalized waveforms of the instantaneous voltages in a three-phase system in one cycle with time increasing to the right. The phase order is 1-2-3. This cycle repeats with the frequency of the power system.

Three-phase systems may also utilise a fourth wire, particularly in low-voltage distribution. This is the neutral wire. The neutral allows three separate single-phase supplies to be provided at a constant voltage and is commonly used for supplying groups of domestic properties which are each single-phase loads. The connections are arranged so that, as far as possible in each group, equal power is drawn from each phase. Further up the distribution system, the currents are usually well balanced. Transformers may be wired in a way that they have a four-wire secondary but a three wire primary while allowing unbalanced loads and the associated secondary-side neutral currents.



Three-phase electric power transmission lines



The phase currents tend to cancel out one another, summing to zero in the case of a balanced load. This makes it possible to reduce the size of the neutral conductor because it carries little or no current. With a balanced load, all the phase conductors carry the same current and so can be the same size.

Most households are single-phase. In Australia, three-phase power might feed a multiple-unit apartment block, but the household loads are connected only as single phase. On a suburban street, every third house will be on the same phase. In lower-density areas, only a single phase might be used for distribution. Some large appliances may be powered by three-phase power, such as electric stoves and air conditioners. In these situations, the power company can connect a household to three-phase power.

Wiring for the three phases is typically identified by colour codes, which vary by country. Connection of the phases in the right order is required to ensure the intended direction of rotation of three-phase motors. For example, pumps and fans may not work in reverse. Maintaining the identity of phases is required if there is any possibility two sources can be connected at the same time; a direct interconnection between two different phases is a short-circuit.

- (a) Explain why three phase power delivers three time more electrical power than single phase. (2 marks)

Each of the three phases provides the same voltage and current as the others, just  $120^\circ$  apart in the cycle. ✓

So total power =  $3 \times IV$  ✓ (energy per second)

- (b) In a three phase power distribution system, the three “neutral” wires are essentially joined and this common neutral wire carries very little current. Explain why this is the case.

(3 marks)

The three phases in the neutral wires sum to zero ✓

for every stage of their cycles. ✓

So there is theoretically no net current in the neutral wire. ✓

- (c) Compared to single phase ac power (or dc), three time as much electrical energy can be transmitted for only 1.5 times the amount of conducting wire. Explain. (2 marks)

Single phase electricity requires 2 wires - active and neutral. ✓

Three phase only needs 3 separate active wires during transmission. So three times the power is transmitted with only 1.5 times the amount of power cable. ✓

- (d) In Australia a three-phase power socket takes a “five pin plug” as shown. Suggest the purpose of each of the five pins.

(3 marks)

Three of the pins carry active for each of the 3 phases ✓

One pin is the shared neutral ✓

One pin is Earth ✓



- (e) After a recent storm in Perth, Hamish noticed that his street had a “partial blackout”. That is every third house in the street had no power. Explain a possible cause of this observation. (2 marks)

It is likely that the transmission cables for one of the phases was damaged. ✓

As the phases are usually balanced along a street, every third house would be on the same phase and therefore without power.

✓

- (f) Briefly explain the operation of a simplified three-phase ac generator, clearly explaining how the three different phases are produced. Make reference to Faraday's Law of electromagnetic induction in your answer. (4 marks)

- Electromagnets rotate past three sets of coils. ✓
- This causes a flux change in each of the coils sequentially ✓
- Therefore an alternating emf is induced in the coils (Faraday's law) ✓
- Each induced emf is  $120^\circ$  out of phase, reflecting the angular separation of the coils in the three phase generator ✓

- (g) If a person were to touch two of the three transmission cables at the same time, could they be electrocuted? Explain. (2 marks)

Yes this is possible ✓

They could still be electrocuted, as there is a potential difference between all cables over time as they are out of phase. Only for an instant are 2 cables at the same Potential ✓

End of Questions



